



## **TP88 Big Button Speakerphone**

**Keep this user guide  
for future reference**

# CONTENTS

<b>Warnings</b> .....	3
Location of Controls .....	4
Features .....	5
<b>PARTS LIST</b> .....	5
<b>INSTALLATION</b> .....	6
Connecting Your Telephone .....	16
Choosing Tone or Pulse Dialing .....	16
Using the Ringer HI/LOW/OFF Switch .....	6
<b>CALLER ID PROGRAMMING INSTRUCTIONS</b> .....	10
Setting the Contrast, Display Language, Area Code .....	10
Setting the Time and Date .....	10
<b>TELEPHONE OPERATION</b> .....	7-9
Answering Calls Using the Handset .....	7
Answering Calls with the Speakerphone .....	7
Making Calls Using the Handset .....	8
Making Calls with the Speakerphone .....	7
Last Number Redial .....	7
Using the Handset Volume Control .....	8
Recall / Flash .....	9
Call Timer .....	9
<b>MEMORY DIALING</b> .....	8-9
Saving Numbers to One-Touch Memory .....	8
Saving Numbers to Two-Touch Memory .....	8
Making Calls from the One-Touch Memory .....	8
Making Calls from the Two-Touch Memory .....	9
Listing your memory Numbers .....	9
Checking a Number Stored into Memory .....	9
<b>CALLER ID OPERATION</b> .....	8-14
When the Caller ID Displays and What the Buttons Do .....	8
Using your Caller ID Phone .....	8
Storing Numbers from the Caller ID into Speed Dial Memory .....	8
Dialing Numbers from the Caller ID Memory .....	8
New Call LED Indicator .....	13
Call Waiting .....	14
Using Message Waiting/Mail Box .....	11
Resetting Message Waiting Indication .....	14
Deleting an Individual Caller ID Record from Memory .....	13
Deleting all Caller ID Records from Memory .....	13
<b>TROUBLE SHOOTING</b> .....	17-19
Wall Mounting Template .....	20



## Warnings

- Do not use your telephone during an electrical storm thunderstorm as it is possible to get an electric shock. Refer to information contained in the White pages directory.
- The earpiece of the handset may attract small metal objects such as staples and pins. Care should be taken when placing the handset near these items.
- Before installing or changing the batteries make sure that the telephone is not connected to the telephone network or the mains power supply.
- All batteries should be replaced at the same time. Mixing fresh and discharged batteries could increase internal cell pressure and rupture the discharged batteries.
- When inserting batteries into this telephone, observe the proper polarity or direction failure may result in leakage or explosion.
- Remove the batteries from this telephone if the telephone will not be used for a long time (several months or more) since during this time the batteries could leak in the telephone.  
Temperature and ambient conditions The telephone is designed for indoor use (temperature range of -10 °C to 50 °C). Do not install the telephone in areas where there is the risk of an explosion, excessive exposure to smoke, dust, vibrations, chemicals, moisture, and heat. The unit must not be installed in damp locations such as a bathroom or laundry, do not expose the unit to direct sunlight.
- The surface of the case can be cleaned with a dry, soft, lint-free cloth. Never use cleaning agents, particularly aggressive solvents. Apart from occasional cleaning of the case, no other care is necessary. The rubber feet of the base station are not resistant to all cleaning agents. The telephone feet do not normally leave any marks on the surface. However, on account of the multitude of varnishes and surface finishes used, surface marks caused by the feet of the unit cannot be ruled out.

## Location of Controls



The A-Tick symbol shows this product complies with all current Australian ACA standards.

- 1. Store Button** - Used to store numbers into the speed dials.
- 2. Recall/ Flash Button** – Used to access telephone dialing features like call waiting.
- 3. Redial Button** - Press for last number redial.
- 4. Speaker Button**- Press to use the speakerphone.
- 5. Speaker LED** - Lights red when the speakerphone is in use
- 6. Speaker Volume Slide** - Slide up or down to adjust the speakerphone volume.
- 7. Auto Button** - Used to recall numbers from 2 touch memories.
- 8. Up and Down button** - Press to step through caller ID records.
- 9. Dial/Set button** - Press to dial the number shown in the display.
- 10. NEW Call LED** - Flashes red when new caller ID information has been received.
- 11. Ring Indicator** - Flashes when phone rings.
- 12. Recall/ Flash Switch** - 100ms Australia, 600ms New Zealand
- 13. Ringer Hi/Lo/Off Switch** - Adjust switch to desired ringer volume setting.
- 14. Caller ID display** - Shows caller ID information and set up options.

15. **Handset Hanger** – Use to put handset on hold if wall mounted
16. **Volume Switch** - Use to adjust the handset receiver volume (NORM or LOUD).
17. **Delete Button** - Press twice to erase a record.
18. **Phone Book** – Used to access the 50 Name and number memories
19. **Memory [M1], [M2], [M3], [M4]** buttons - Press to dial speed dial numbers.
20. **Reset Switch** – Located on the base of the phone

## Key Features

### Caller ID:

- Displays the caller's name and telephone number, plus the date and time of the call, for the last 100 incoming calls that you have received (where service is available and has been subscribed to)
- Extra large three-line high resolution LCD display.
- Displays in standby screen total and new calls received.
- Up/Down buttons allow easy scrolling forward or backward through stored call records.
- Delete button allows call records to be Deleted individually or collectively.
- Real Time Clock - Time and date will be automatically set up by the local telephone company when caller ID information is received.
- Allows you to call back a number from the caller ID memory.
- Quick store of caller ID information into speed dial
- Adjustable display contrast and viewing angle
- New Call LED indicator
- Voice Mail Message waiting indicator on display
- Multi-Language Selectable - Allows you to select English or 1 of 7 other languages.

### Key phone features:

- Speakerphone - Allows hands-free conversation
- Four one-touch Speed Dial Buttons (**M1** to **M4**) - For quick dialing of frequently dialled numbers
- Twelve two-touch Speed Dial Buttons (**MEM 0** to **MEM #**) - Dials twelve stored numbers with the press of two buttons
- Last Number Redial
- Handset Volume Control - Adjusts the volume of the handset receiver between two levels: Normal and Loud
- Desk or Wall Mountable (fits standard Australian wall mounting plate)

## PARTS LIST

Unpack the unit and check to be sure you have all the items below.

- Telephone Base and handset
- 1 Curly Handset Cord, 1 Long and 1 short line Cord
- Desk/Wall Mount Bracket, Memory Index Label
- 4 X AA Batteries

## Installation of Batteries

**Note:** Before installing or changing the batteries make sure that the telephone is not connected to the telephone network or the mains power supply.

To open the battery door and install the batteries, follow the procedure below:

1. Open the battery door on the bottom of the base by using the tip of a screwdriver to lift the latch.
2. Install the 4 AA batteries (supplied) into the battery compartment observing the correct polarity.
3. Close the battery compartment.

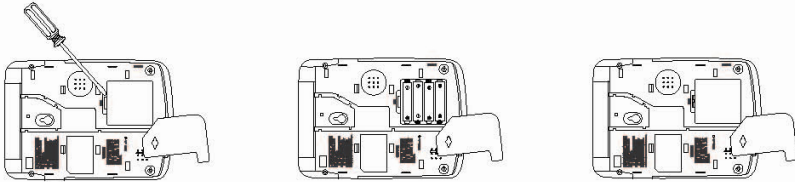

### Low Battery Alert

This unit will alert you when the batteries need replacement. When the battery power becomes low the display will become dim. When you need to replace batteries in the future always use high quality AA batteries. The batteries are needed for memory backup.

#### **WARNING:**

- Replace the batteries when the LCD Screen becomes dim.
- When the batteries are flat, the LCD Screen will be blank. You can still make or receive calls, but you cannot use the Caller ID feature, memory dialing and your data and settings may be erased.

### Using the Ringer HI/LOW/OFF Switch

The ringer switch is located on the back of the phone. Select the desired level for the ringer.

HI - Allows your telephone to ring loudly on incoming calls.

LOW - Allows your telephone to ring softly on incoming calls.

OFF - Turns off the ringer for undisturbed privacy.

**Note:** If your RINGER switch is in the OFF position, only this phone will not ring, other phones in your home on the same line will still ring.

# TELEPHONE OPERATION

## Answering and making Calls Using the Handset

The TP88 is used like any conventional phone, in addition, the speaker phone keeps your hands free, which makes phoning considerably easier for you. When the telephone rings, allow it to ring twice so caller ID information is received.

## Answering Calls with the Speakerphone

1. When there is an incoming call, ringing is heard. If you are subscribed to caller ID service, the caller information is shown after the first ring.
2. To answer the call, press the **SPEAKER** button, and begin to speak. The Speaker LED indicator will light. After 8 seconds the call timer will begin keeping track of the elapsed time for the phone call. It is not necessary to lift the handset. Always wait for the second ring to occur before pressing the speakerphone button in order to get caller ID information.
3. To end the call, press the **SPEAKER** button again.
4. The Speaker LED indicator will go off and the display will return to the idle screen.

## Making Calls with the Speakerphone

1. Press the **SPEAKER** button to get dial tone without lifting the handset. The Speaker LED indicator will light.
2. When you hear the dial tone, dial the telephone number for the party you wish to reach. The number dialled will show in the LCD. After ten seconds the call timer will begin keeping track of the elapsed time for the phone call.
3. Adjust the speakerphone volume by sliding the speakerphone volume control located on the right side of the telephone.
4. To hang up, press the **SPEAKER** button again.
5. The Speaker LED indicator will go out and the display will return to the standby screen.

### Notes:

1. *If a squealing or whistling sound is heard, reduce the volume setting.*
2. *If you want to switch from the handset mode to speakerphone mode, press and hold the **SPEAKER** button whilst replacing the handset. Then release **SPEAKER** button.*
3. *To switch from the speakerphone to the handset, just lift the handset.*
4. *Remember to hang up by pressing the **SPEAKER** button at the end of the conversation.*
5. *If it is difficult to transmit because of a high background noise level in the other party's environment or telephone line noise, lower the volume level.*
6. *In order for caller ID information to be received properly, do not press the **SPEAKER** button or pick up the handset before the second ring.*

## Using the Handset Volume Control

You can adjust the volume level of the handset receiver by adjusting the volume control on the side of the handset during a conversation. There are two levels to adjust between: Normal and Loud (NORM-LOUD).

## Last Number Redial

The TP88 will store the last 16 numbers you called. These are redialled as follows.

1. To redial the last number leave the handset on the base, press REDIAL repeatedly until you find the number you wish to dial.
2. When you find the number you wish to dial press the **SPEAKER** button or pick up the handset. The number will now dial.

## Saving Numbers to One-Touch Memory (M1 to M4)

**Note:** When storing memory numbers, your phone must have batteries installed.  
**NUMBERS ONLY CAN BE STORED IN THESE MEMORIES.**

1. With the phone on-hook, Dial the number you wish to dial (up to 16 digits) using the dial pad.
2. Then press the **STORE** button
3. Press the one-touch memory button that you wish to store the number in ([M1], [M2], [M3] or [M4]). The number is now stored.
4. Repeat steps 1 to 3 to store other numbers.

## Saving Numbers to Two-Touch Memory (MEM 0 to MEM #)

1. Dial the number you wish to dial (up to 16 digits) using the dial pad.
2. Press the **STORE** button once.
3. Press any number on the dial pad that you wish to store the number in ([0] to [#]). The number is now stored.
4. Repeat steps 1 to 3 to store other numbers.

**Note:** There is a time-out for storing numbers. If the TP88 times out before the number is stored, try again.

## MEMORY DIALING

### Making Calls from the One-Touch Memory

Follow the instructions below to dial a number from the one-touch memory:

1. Pick up the handset, or press the **SPEAKER** button to get a dial tone.
2. Press the memory number ([M1], [M2], [M3] or [M4]) button where the number is stored.
3. The number will be displayed and your call will be automatically dialled exactly as you programmed.



## **Making Calls from the Two-Touch Memory**

Follow the instructions below to dial a number from the two-touch memory:

1. Pick up the handset, or press the **SPEAKER** button to get a dial tone.
2. Press the **AUTO** button, and then the dial pad button where the number is stored.
3. The number is dialled automatically.

### **Notes:**

1. You may program a "Pause" into memory (e.g. when you need to dial a **9** to get an outside line). While storing a number, press the **[REDIAL]** button (a "P" will show on the display).

## **Listing Your Memory Numbers**

Write names and numbers on the Memory Index Label in pencil so that you can change them later. This also allows you to easily reprogram the phone in the rare cases where memory is lost.

## **Checking a Number Stored into Memory**

1. With the phone on-hook, press **AUTO** and the memory button(s) for the location you wish to view. The display will show the location and the stored number.
2. In case you want to change a number you stored, simply store a new number into that location. The old one will be erased automatically.

## **Call Timer**

About 5 seconds after the number you have called is dialled, an automatic call timer will start to count up on the display. This is useful since it allows you to know how long you have been talking on the phone (it is especially useful when making a long distance call).

## **Recall Switch**

Many special network services, such as call waiting, require a recall signal. The **RECALL** button provides this signal. For example, if you subscribe to Call Waiting, you can put your current call on hold when you hear the beeps and answer another call on the same line by pressing **RECALL** button, listen for dial tone then press 2. Press **RECALL** and 2 again to alternate between the two calls.

# MENU PROGRAMMING INSTRUCTIONS

The TP88 has a simple menu system used to handle set up phone book operation.

## Accessing the Menu

With the handset on the base, press DIAL/SET to enter the menu mode, and LCD will display: VIEW MENU ↓↑.

Use UP or DOWN button to move through the menu. When you choose one item, press SET again to set. After you finish with one item, you should press SET again in order to confirm and/or move to another item.

To change items, always use the UP or DOWN button. If you want to leave the menu mode at any time, press DELETE.

## SELECT LAUGUAGE

The TP88 is defaulted to select the “English” language. Twelve seconds after the batteries are installed. To change simply:-

1. Press **DIAL/SET** use **UP** or **DOWN** to select: **\_SELECT LANGUAGE**.
2. Press **SET** you will see on the display ENGLISH which is the default setting. Use **UP/DOWN** to change another language (English / French / Spanish / Italian /German / Turkish/ Polish / Slovenian) which you want. Press **SET** to confirm.

## SETTING DATE/TIME

If you subscribe to caller ID the Time and date will be set up automatically when the phone rings. If no caller ID is activated you can set the time and date manually

1. Press **DIAL/SET** use **UP** or **DOWN** to select: **DATE/TIME**, press **SET**, the year digits will flash.
2. Use **UP/DOWN** to select the year then press **SET**. Repeat the operation to set the, hour, minute, month and date.

## LCD CONTRAST

1. Press **DIAL/SET** use **UP** or **DOWN** to select: **CONTRAST ADJUST**, press **SET** and use **UP/DOWN** to select among 5 degrees, which you prefer.

**NOTE: The default setting is 3.**

## USING THE NAME AND NUMBER PHONE BOOK

### Adding Names and Numbers

You can store 50 names and Numbers in the phone book.

1. Press **DIAL/SET** use **UP** or **DOWN** to select: **PHONEBOOK ADD**
2. Press **SET**, The LCD displays **INPUT NUMBER** now enter the number you wish to store including the area code and IDD prefix, EG 02 91234567
3. Press **SET** to confirm. The LCD shows **ENTER NAME** now enter the name, for example, digit [2] button will store A, B and C. Pressing [2] button once will give you the letter "A" and twice will give you "B".
4. Use **UP/DOWN** to move the cursor and **DELETE** to correct. When finished, press **SET** again to confirm. For exit, press **DELETE**.

### Legend of letters and symbols in numeric keypad:

[1] 1	[7] P Q R S 7
[2] A B C 2	[8] T U V 8
[3] D E F 3	[9] W X Y Z 9
[4] G H I 4	[0] 0 . -S pace
[5] J K L 5	[*] *
[6] M N O 6	[#] #

## **EDITING PHONE BOOK ENTRIES**

1. Press **DIAL/SET** use **UP** or **DOWN** to select: **PHONEBOOK EDIT**.

1. Press **SET** and input the first character of name you wish to edit. You can then view the corresponding telephone numbers by pressing **SET** again. If no character input, you could use **UP and DOWN** to view all the entries in sequence. When you find the number you want to edit.
2. Use **UP/DOWN** to move the cursor and **DELETE** to correct. When finished, press **SET** again to confirm, to exit press **DELETE**.

### **Dialling items from the Phone book**

1. Press **PHONE BOOK** button and input the first character of the name you wish to dial. Or keep pressing **PHONE BOOK** until you find the number.
2. To dial press **DIAL/ SET** or **SPEAKER**. The number will dial automatically.

## CALLER ID

If you subscribe to your telephone operators Caller ID service, the incoming callers number will be displayed on the screen and stored in the call log.

(Please consult your telephone service provider for details, service charges may apply)

### CALLER ID OPERATION:

When receiving a phone call, the display will show the phone number together with the information, date, and time of the call. A new number will carry a "NEW" icon, and a repeated number will carry a "REP" icon. A private call (when the caller prefers his/her number to be hidden) will display "PRIVATE CALL". A call out of service will display "UNAVAILABLE". An incorrect incoming signal will display "LINE ERROR". If you have programmed the memories with Names the corresponding name will be displayed also. the name shown on the LCD will be same as that in the phone book.

### Checking incoming calls

1. Use the **UP/DOWN** buttons view the information of the incoming calls including phone number, date, and time. To scroll rapidly, press and hold **UP/DOWN**.
3. When the caller ID memory is full, the oldest calls will be automatically deleted in order to make room for the new caller ID numbers.

### Dialing Numbers from the Caller ID Memory

The TP88 allows you to dial a phone number stored in its caller ID memory. This is the "call back" feature of this phone. To dial a number from caller ID memory, do the following:

1. With the handset in the base, press the **DOWN** or **UP** button to find the caller ID entry you wish to dial.
2. Press the **DIAL/ SET** button to enter caller ID call back mode. The number will appear on the display then automatically dial.

### CALLER ID OPERATION

#### Deleting an Individual Caller ID Record from Memory

1. Press **DOWN** or **UP** until the call to be deleted is displayed.
2. Press **DELETE** once, the LCD shows "DEL?", then press **DELETE** again within two seconds.
3. The call is deleted and the total call count in the display is reduced.

#### Deleting all Caller ID Records from Memory

You can only delete all calls after all calls have been reviewed. If there are any new call

records, deleting all calls will not work.

1. Press **DOWN** or **UP** to view any caller ID call information.
2. Press and hold **DELETE** for five seconds until “**DEL ALL?**” is displayed.
3. All calls are Deleted and the total call count in the display returns to zero.

C

### **New Call LED Indicator**



The NEW CALL LED indicator will flash slowly to alert you if there have been any new incoming calls. The display will also indicate the number of new calls.

The NEW CALL LED indicator will keep flashing until you have reviewed all new calls. The “NEW” (new call number) counter on the display will become zero.

### **Using Message Waiting / Mail Box**

**NOTE: If you are using Telstra Messages 101 you will need to contact Telstra and request they enable the FSK signalling on your line**

This product is designed to receive (FSK) Message Waiting indication from your Telephone service provider. For this feature to work, you must subscribe to this service with your local telephone company.

1. When a message is preceded by a ring is sent by telephone service provider, the Message Waiting symbol  will only appear on the display, and the NEW CALL LED will then flash.
2. After you have retrieved your message(s), the telephone company should send a clear signal to your phone. The Message Waiting symbol  will turn off until a new message is received.

### **Resetting Message Waiting Indication**

The telephone company sometimes will not send a message clear signal to you, and then you will have to clear the message waiting indication manually. See trouble shooting section.

### **DESK AND WALL MOUNTING**

Your TP88 can be mounted to a standard wall phone plate. If you do not have a modular wall phone plate installed, consult with your phone company or licenced installer to get one, or install without a wall plate. NOTE: Screws and wall anchors are not supplied.

1. **HANDSET CLIP** - When the phone is mounted on the wall, the **HANDSET CLIP** must be adjusted so it will hold the **HANDSET**.

A. SLIDE OUT

B. REVERSE

C. SLIDE INTO PHONE

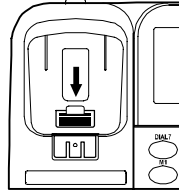
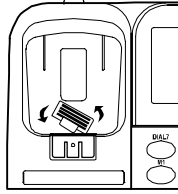
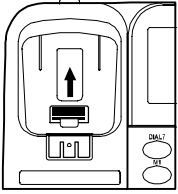

*Wall*

MOUNTING BRACKET:

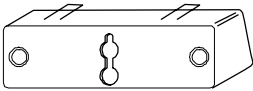

FOR WALL USE, PUT BRACKET HERE

2. Insert the **HOOKS** of the **MOUNTING BRACKET** into the matching slots on the back of the **BASE UNIT** (as shown).

3. Connect one end of the **SHORT TELEPHONE LINE CORD** into the **TELEPHONE LINE CONNECTION JACK** on the back of the **BASE UNIT**

4. Feed the **SHORT TELEPHONE LINE CORD** into the channel in the bottom of the **BASE UNIT** and plug the other end of the **SHORT TELEPHONE LINE CORD** into the **WALL JACK**.

5. Position the **WALL MOUNT SLOTS** on the bottom of the **BASE UNIT** over the two wall plate studs. Then slide the **BASE UNIT** down to lock the phone onto the **WALL PLATE**.

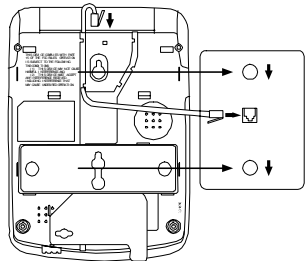
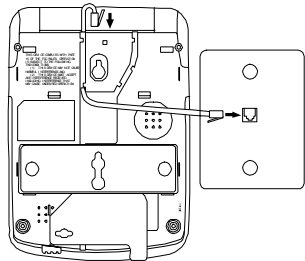
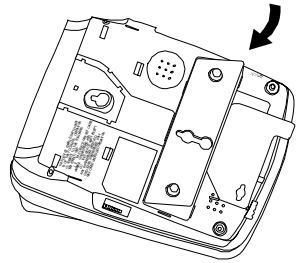

## Wall Mounting without a Modular Wall Phone Plate

1. Locate a wall stud. If the selected area does not have a wall stud directly behind it, use dry wall expanders or a similar type fastener.
2. Drill 2 6mm holes 100 mm apart, as per template at the end of this user guide.
3. Fix a screw (not supplied) into each hole and leave 5mm of the head exposed to mount the phone.
4. Connect the TELEPHONE LINE CORD to the **BASE UNIT** and the wall jack.
5. Position the WALL MOUNT SLOTS on the bottom of the **BASE UNIT** on the 2 mounting screws and gently push down to lock into place.

### IMPORTANT:

Before mounting the **BASE UNIT** on the wall, consider the following:

The location should be away from electrical cables, pipes, or other items behind the mounting location. Inserting screws into areas such as these can be dangerous. The location of the phone should be within 2m of the telephone socket.

### Installation on Masonry

1. Using a 6mm masonry drill bit drill the 2 holes using template.
2. Insert 2 plastic anchors and install the 2 screws.
3. Leave 5 mm of the screws exposed to mount the phone.
4. Position the WALL MOUNT SLOTS on the bottom of the **BASE UNIT** on the 2 mounting screws and gently push down to lock into place.

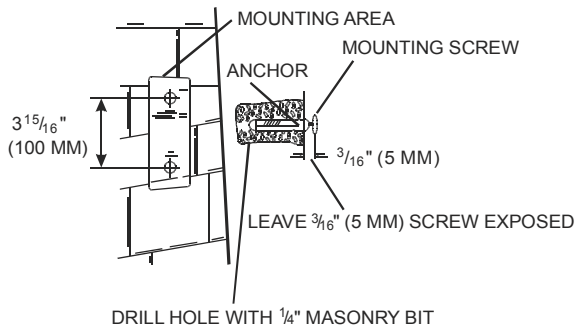



# TROUBLESHOOTING

## **No dial tone/phone will not dial out.**

- Check all telephone cord connections or try another wall socket.

## **Can't hear the phone ring.**

- Verify the ringer switch is not set to "Off."

## **Other party cannot hear you.**

- Ensure handset cord is connected properly.

## **Display showing erroneous figures OR Display does not work as intended.**

- Enter the telephone setup by pressing the **DELETE** button and then the **DOWN** button. After that, reset the settings, especially language, area code.
- If the problem persists, your phone may need to be reset by removing the batteries. Wait for 5 minutes before reinstalling the batteries. This will also clear all memories. The caller's name and/or phone number does not appear on the display.

## **Caller ID is not working properly.**

- Make sure you subscribed to caller ID service from the local telephone company and that the service has been activated.
- You answered the call before caller ID data was displayed, which usually occurs after the first ring.
- Caller ID may not work when the phone is connected to an office phone system (PBX).

## **The display is faded** (Numbers are hard to see)

- Check the contrast setting.
- Verify that the batteries are correctly installed.
- Change all four batteries, making sure to replace all four batteries with fresh batteries at the same time.

## **Cannot store numbers into memory**

- Make sure batteries are installed, installed correctly to match the proper polarity, and are not weak.

## **Message Waiting Indicator doesn't work properly.**

- If you are using Telstra Messages 101 you will need to contact Telstra and request they enable the FSK signalling on your line

## **Resetting Message Waiting Indication**

The telephone company sometimes will not send a message clear signal to you, and then you will have to clear the message waiting indication manually. To reset this you must: Remove the batteries in the product and reinstall the batteries after 5 minutes.

**Note:** *Caller ID memory loss as well as one and two-touch memory loss may occur when resetting. Therefore, please make sure that you record all important information before you proceed with the reset.*

### **Handset falls out of phone base when wall mounted**

Handset clip was not installed properly for wall use

### **LINE ERROR appears on the LCD panel**

- Your phone received no information or unclear call information. Static can cause this message. If this condition persists, contact your local telephone company to ensure that there is no problem with your phone line.
- You might have answered the phone before 2 rings.

### **Cannot erase all records in memory**

- The **DELETE** button must be quickly pressed twice to erase a single call record. You must view all new calls before you can delete all calls. To erase ALL call records, press and hold the **DELETE** button for at least 5 seconds after you view all new calls.

### **The Caller ID display is blank**

- Press either **UP** or **DOWN** button to see if “- NO CALLS -” appears.
- Check if batteries are properly installed.
- Check if you have received the first caller ID record.

### **Memory Dialing does not work**

- Check the phone if you have programmed the numbers correctly by pressing that memory number button. Also programming can only be done if fresh batteries are installed correctly.

### **Caller's information is not registered**

- The caller may have an unlisted or blocked number to prevent caller ID identification, it may be an overseas call, or you may have had noise on the line during that call.
- You answered the call before caller ID data was displayed, which usually occurs after the first ring.

### **Pressing a memory button does not display number**

- Your memory button has no stored number. Please store the number again by pressing the **[STORE]** button, dialing the number and pressing the memory location button where you want to store the number.

## **Technical support**

In the unlikely event of a fault during this period, please consult our website for assistance or send us an email for a prompt response to your enquiry. If the product is then found to be faulty you will be asked to return it directly to us with a copy of the purchase receipt.

## **Warranty**

**Always retain your proof of purchase (receipt) from the retailer as this will be needed for any warranty claim.**

This product is covered by a 12 month warranty against defective workmanship or parts, effective from the date of purchase.

The warranty does not extend to damage caused by misuse, negligence, excessive voltage, faults on the telephone line or lightning. The warranty is only valid in the country of purchase. This warranty in no way affects your statutory rights. Full details of the warranty are contained in the enclosed warranty card.

For further information about the Oricom range of products please visit our website or contact us using the information below. REGISTER YOUR PRODUCT ON LINE.

## **Oricom International Pty Ltd**

ABN 46 086 116 369

PO Box 5681

South Windsor, NSW 2756

AUSTRALIA

## **Customer support**

Email: [support@oricom.com.au](mailto:support@oricom.com.au)

Web: [www.oricom.com.au](http://www.oricom.com.au)

Fax: (02) 4572 0939

Phone: 1300 889 785

## Wall Mount Template

This page serves as a template for attachment of screws to the wall when mounting this telephone on the wall.

1. Cut out this page.
2. Use this template to determine the distance between screws when mounting this phone on the wall. The two cross hairs identify where to attach the screws.

